

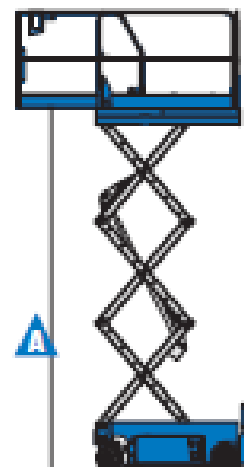

Specifications

		GN-3246 GTJZ1012	GN-4047 GTJZ1212
	Working height*	12 m	13,9 m
A	Platform height	10 m	11,9 m
C D	Platform dimension (length x width)		
	- with the tray up	2,25 m x 1,15 m	2,25 m x 1,15 m
	- with the tray down	3,15 m x 1,15 m	3,15 m x 1,15 m
E	Height - stowed	1,86 m	1,98 m
F	Length - stowed	2,39 m	2,39 m
G	Width	1,15 m	1,15 m
I / J	Ground clearance	10 cm	10 cm
Productivity			
	Max platform occupancy (indoor / outdoor)	2/1	2/1
	Lift capacity	320 kg	320 kg
	Drive speed - stowed	3,2 km/h	3,2 km/h
	Drive speed - raised	0,8 km/h	0,8 km/h
	Gradeability**	25%	25%
	Turning radius - inside	zero	zero
	Turning radius - outside	2,35 m	2,35 m
	Raised / lower speed	55/42 sec	65/47 sec
	Controls	proportional	proportional
	Tyres – solid non-marking	38 cm x 12,5 cm	38 cm x 12,5 cm
Power			
	Power source	24V DC (4 maintenance – free batteries) 6V 240 Ah	24V DC (4 maintenance – free batteries) 6V 300 Ah
	Hydraulic system capacity	22 L	22 L
Sound and Vibration levels			
	Sound pressure level - ground	<70 dBA	<70 dBA
	Sound Pressure level - platform	<70 dBA	<70 dBA
	Vibration	<2,5 m/s ²	<2,5 m/s ²
Weight***			
		2,570 kg	2,900 kg
CE – Standard Compliance		EC Directives: 2006/42/EC – machinery EN280:2013); Directives 2004/108/EC (EMC); Directives 2006/95/EC (LVD)	

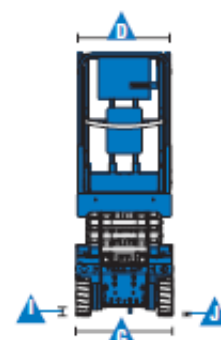
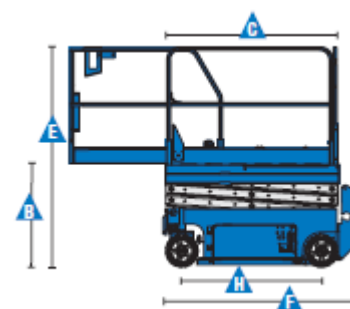

* the metric equivalent of working height adds 2m to platform height.

** gradeability applies on driving on slopes. See operator's manual for details regarding slope ratings

*** weight will vary depending on options and/or country standards





Features

Standard Features

GN-3246 (GTJZ1012)

- 12 m – Working height
- 320 kg – Lift capacity

GN-4047 (GTJZ1212)

- 13,9 m – Working height
- 320 kg – Lift capacity

Equipment

- Electrostatic powder coating system
- Unical platform stability, construction is much more solid, platform extension smoothly operated
- Solid floor made of anti-slippery, riffled metal sheets
- Durable steel protection railings with openable gate
- Easily removable riffled-surface steps
- Option of connecting working light (connection line and attachment points for spotlight)
- Handles for crane lifting
- Drive motors protection, hydraulic hoses protection
- Machine prepared for either side or back forklift loading
- Side protection pads on the chassis and components swing-out trays
- Stable and solid swing-out electric and hydraulic components trays – key lockers
- Onboard electronic system DELTA 5, USA, possible calibration without PC
- Platform control joystick with battery charge indicator
- Fully proportional joystick for left or right handed users
- Emergency stop at both platform and ground controls
- Battery charging access point on the side of the machine
- 230 V electric line to platform with circuit breaker protection
- Manual platform lowering valve
- Front wheel hydraulic dynamic braking
- Manual hydraulic brake release
- Electronic horn
- Tilt level sensor with audible alarm
- Hour meter
- Certified load sensor
- Flashing LED beacons

Standard Features

Power

- Universal 25 AMP smart charger

GN-3246 (GTJZ1012)

- 24V DC (4 maintenance – free batteries) 6V 240 Ah

GN-4047 (GTJZ1212)

- 24V DC (4 maintenance – free batteries) 6V 300 Ah

Drive

- Hydraulic ,dual front wheel drive

Tyres

- Solid, non-marking

Additional Options

- Airline to platform
- Biodegradable hydraulic oil
- Maintenance free lithium battery, Gell battery or AGM battery option
- Individual painting colors selection on demand
- Parktronic System (parking sensors set).
- Option of 2 working lights mounted at the end of platform (LED spotlight)



**ECO Lithium
Technology**



**Bio Degradable
Option**

